

termont S

Stove-boiler for solid fuels 10-25 KW

Directions for use and assembling



Servis:

Termomont d.o.o. Prhovačka bb 22310 Šimanovci
tel. 022 80404, 022 80494 fax 022 80494 www.termomont.rs

April 20, 2010

Contents

1	Technical data	2
1.1	Boiler properties TEMY S 10-25 KW	3
1.2	On Product	3
1.3	Boiler shipment and storage	3
1.4	Delivery	4
2	Boiler installation	4
2.1	Fitting the boiler to a closed central heating system	4
2.1.1	Installation method 1	4
2.1.2	Installation method 2	5
2.2	Fitting the boiler to an open central heating system.	6
2.3	Filling up the boiler and installation with water	7
3	Boiler operation	7
4	Chimney	8
5	Boiler cleaning and maintenance	9
A	Declaration Of Conformity	10

1 Technical data

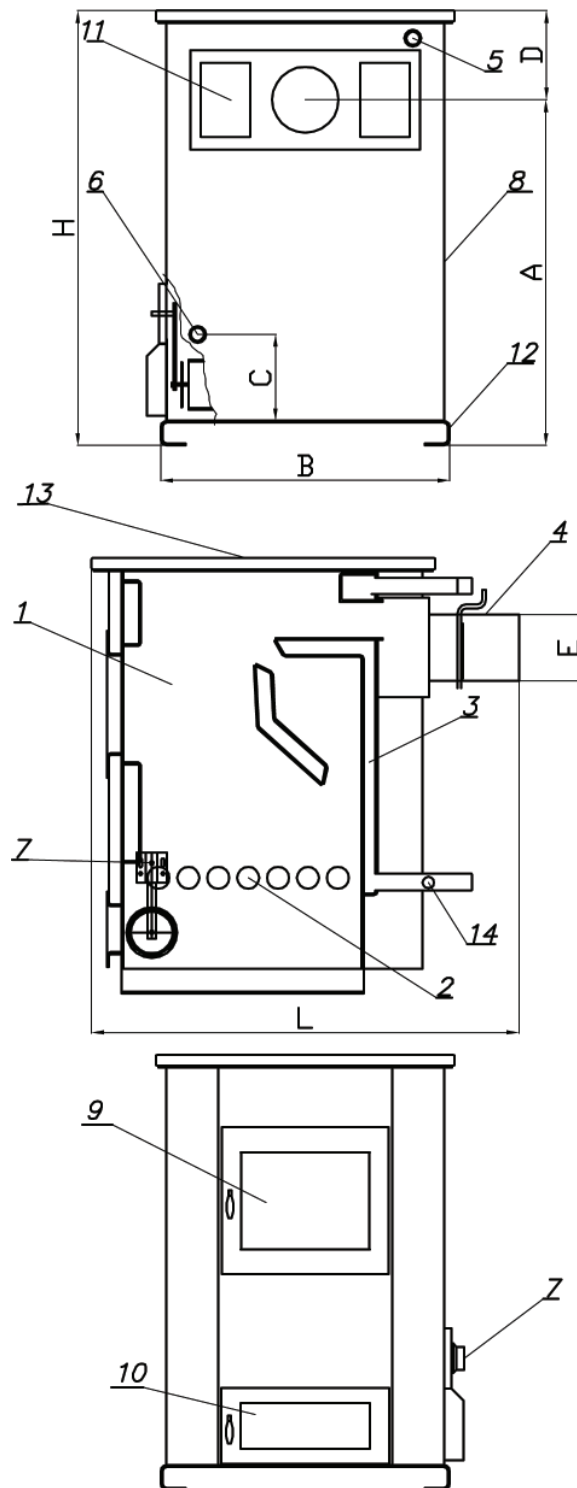

Boiler part description: 1. Heating chamber 2. Water cooled grid 3. Hot water 4. Flue flap 5. Flow line 6. Return line 7. Flue 8. Automatic draught regulator 9. Temperature and pressure meter 10. Mountaing place for thermal safety device 11. Opening for cleaning 12. Fill and drain tap 13. Secondary air inlet

1.1 Boiler properties TEMY S 10-25 KW

1. Overall nominal power (kW)	10	15	25
2. Necessary draught (Pa)	12	13	14
3. Water content (l)	25	45	60
4. Max working temperature	90 °C	90 °C	90 °C
5. Max working pressure	3 bar	3 bar	3 bar
6. Weight (kg)	106	160	178
7. Outer flue diameter (mm)	118	128	148
8. Width	440	540	600
9. Height	815	830	880
10. Depth	660	810	850
11. Upper door (mm)	258x196	258x196	258x196
12. Lower door (mm)	258x92	258x92	258x92
13. Flow	1"	1"	1"
14. Return	1"	1"	1"

1.2 On Product

TEMY S is a steel hot-water stove-boiler for central heating with possibility to cook in the same time, produced according to EN 12809. It is very easy to use and maintain.

Boiler chamber is entirely made of steel, while the front parts are made of stainless steel AISI 314. The door frames are made of cast-iron. The upper door is made of fireproof glass, while the lower door is made of steel. The lower door has secondary air inlet for better combustion.

The flue opening is placed on the back side of the boiler. Hot-water volume inside the boiler is high (up to 60 l) - the fact which guarantees functionality of the product as a central heating boiler. It has no insulation coating around, so that the heat radiation is spreaded toward the ambience directly (around 1 kW). The heat radiation toward the cooking plate is 1-2 KW. The rest is given to the central heating system.

TEMY S has the embedded automatic draught regulator (Rathgeber, made in Germany) provided:



Automatic draught regulator is to be found on the lateral side of the boiler.

1.3 Boiler shipment and storage

The boiler must always stand in its vertical position. The rotation of the boiler during the shipment or installation represents a serious risk and can lead to damaging the boiler. It is forbidden to place one boiler onto another. The boiler can be stored only in closed rooms with no atmospheric influence. The

humidity in the storing room also must not exceed the critical value of 80%, so as not to create any condensate. The temperature of the storing room must be in the range of ± 40 °C.

When unpacking the boiler, you must check whether the paint on the boiler coating has been scratched somewhere and whether all parts of the boiler stand in their proper position.

1.4 Delivery

Boiler is delivered with the housing premounted on the boiler body. Together with the boiler, also the following parts are supplied:

- Boiler thermo-manometer
- Cleaning kit
- Boiler guarantee and certificate

2 Boiler installation

2.1 Fitting the boiler to a closed central heating system

Depending on the position of the boiler in relation to the pipe-work and the radiators – the installation can be carried out using one of two methods.

2.1.1 Installation method 1

If the boiler is positioned on the same level or higher than the pipe-work and radiators.

Each of the following items of equipment shall be fitted along the flow line:

1. Aeration vessel.
2. Safety valve (spring valve is recommended).
3. Expansion vessel.
4. Boiler valve.

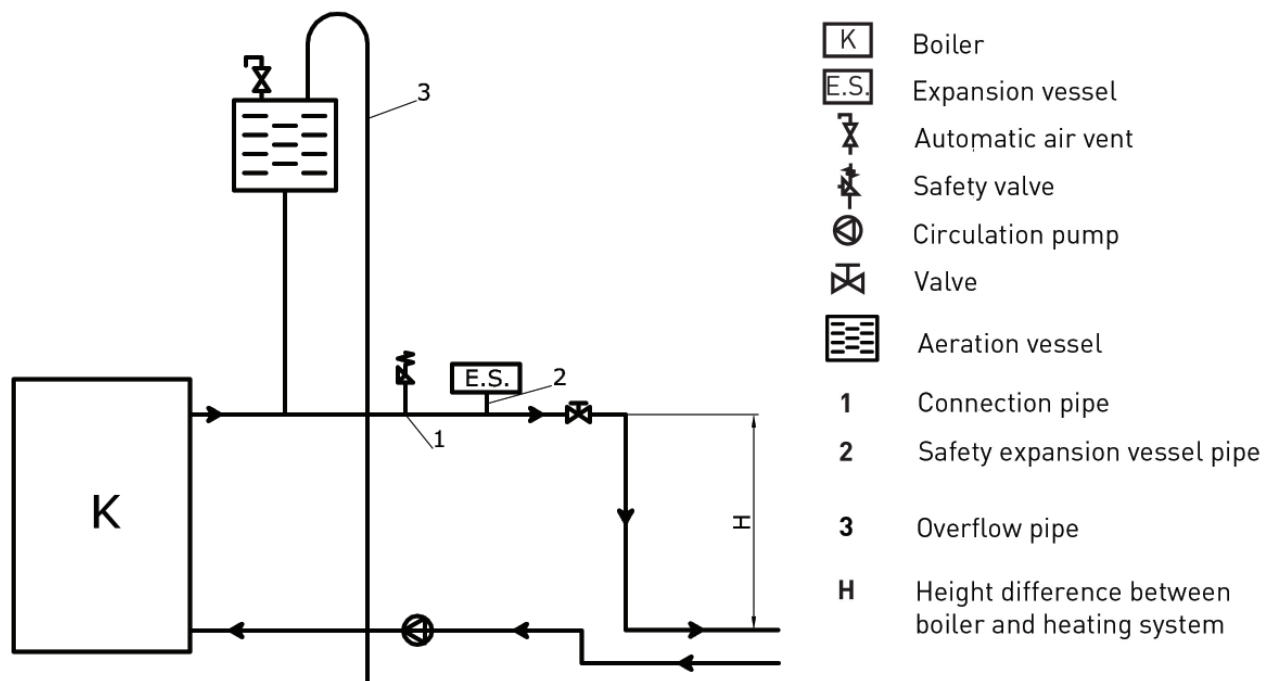

Aeration vessel to be fitted at highest point of the system at top of boiler outlet. This should include an overflow system with valve to discharge air from the boiler to prevent overheating.

A float operated valve allows water into a cistern fitted with an overflow pipe. When the system is filling, the valve remains open. When the system is full the valve closes.

Temperature of hot water within a storage system. Irrespective of the type of fuel used for heating, the temperature of the water at any point within a hot water storage system should not exceed 100 °C and appropriate vent pipes, temperature control devices and other safety devices should be provided to prevent this occurring.

Safety Pressure Valve (PSV). The safety pressure valve must always be positioned and mounted close to the boiler. It must be easily identifiable and allow for easy access. The safety pressure valve must be set to a nominal pressure of 2.5 bar. The valve must open and operate smoothly at 2.5 bar. Diameter for the aperture at the seat of the valve must be at least 15mm. Connecting pipe-work to the boiler must be as short as possible. Welds, joints or any possible blockage to this pipe-work must be prevented.

Bends in the pipe-work should be avoided if possible. Unavoidable bends should be at diameter $r > 3D$ (D = radius of curvature) and less than $\alpha > 90$ ° C.

Closed expansion vessel. The closed expansion vessel shall be fitted close to the boiler. Connecting pipe-work should be as short as possible. Fit the expansion vessel in horizontal alignment to the pipe to ensure equal distribution of pressure. The volume of the expansion vessel is determined by the output/capacity of the boiler. A ratio of 1 kW:1 litre should be used.

The safety pressure valve and the expansion vessel should be fitted in close proximity to each other, in the following order: expansion vessel closest to the boiler, followed by the safety pressure valve.

It is also recommended to mount a dirt remover on the RETURN line. In the event of power failure and the boiler fails to operate correctly – any sudden increase of pressure will be controlled first by the expansion vessel, on any further increase in pressure the safety pressure valve will open.

Great care must be taken to ensure air does not enter the boiler.

2.1.2 Installation method 2

To be used in the case of the boiler being positioned and installed at a lower level than the installed pipe-work and radiators.

As shown on Figure, following elements are connected along the FLOW:

1. Automatic air vent
2. Safety valve
3. Circulation pump (separated with ball valves on each side so that it can be easily replaced if necessary).

For safe operation info on additional equipment such as expansion vessel and safety valve please refer to manuals to be delivered with such products.

This air vent valve must be open when first filling the boiler on installation completion.

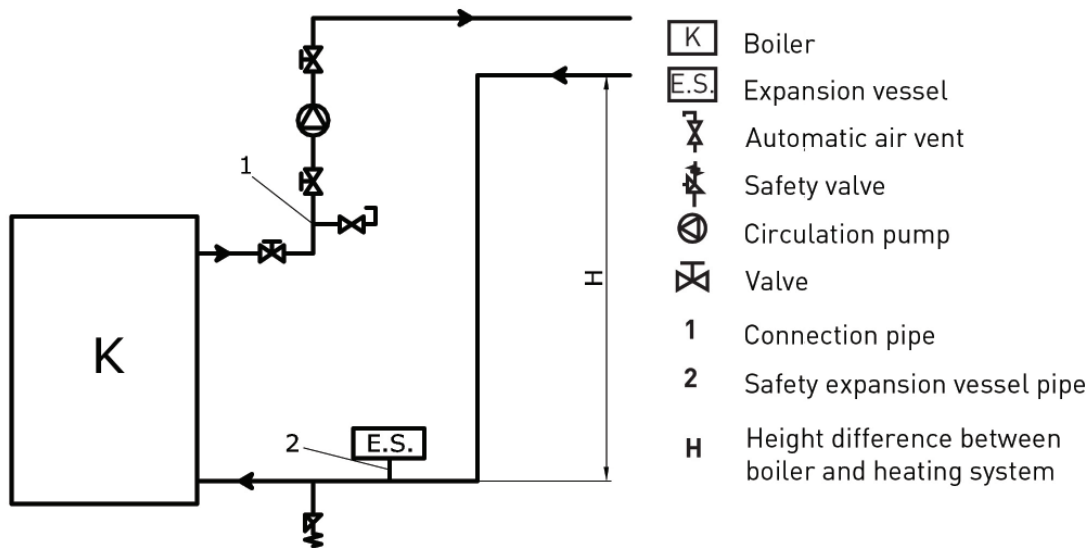

2.2 Fitting the boiler to an open central heating system.

The connecting scheme of an open central heating system is depicted on the figure.

Open expansion vessel is connected to the hot-water distribution pipes (FLOW and RETURN) as shown on Figure – with an additional OVERFLOW pipe output plus CIRCULATION pipe (to prevent freeze during winter months).

Please note that no additional items shall be connected to the open expansion vessel – especially not valves.

The size of expansion vessel is deducted from the following equation:

$$V = 0,07V_{water}(l)$$

$V_{water}(l)$ is the water volume in the entire installation.

Open expansion vessel is to be positioned vertically above the highest heating element.

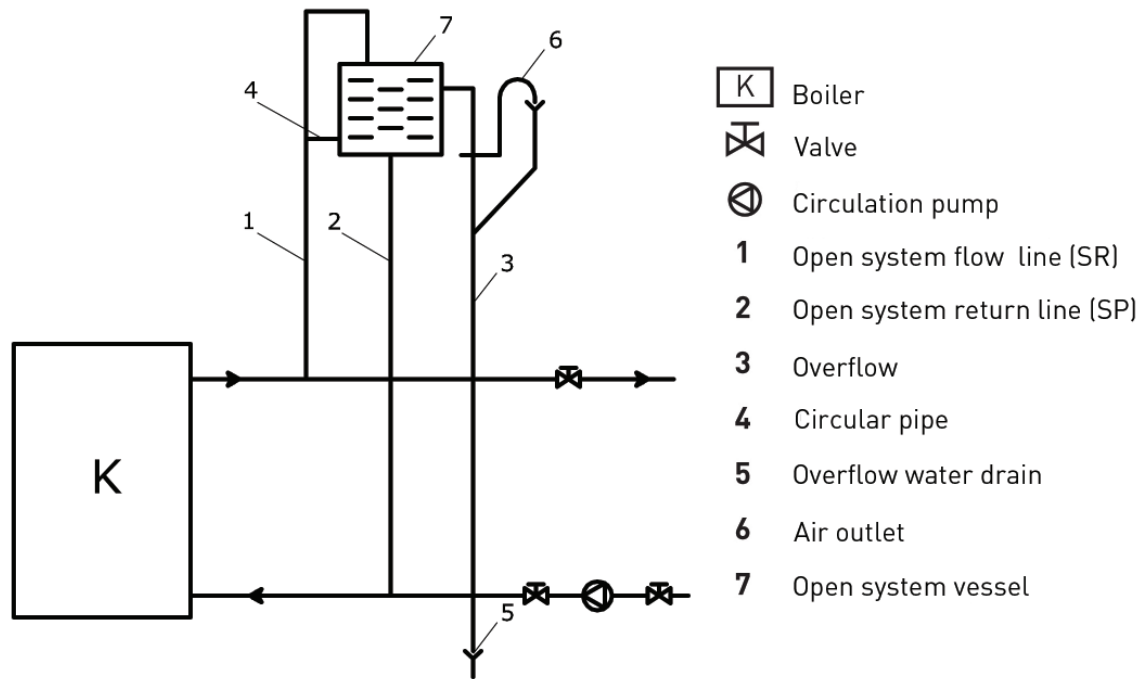

2.3 Filling up the boiler and installation with water

Filling is done using the drain tap valve (to be found on the return line close to boiler). The filling process is done when no air is coming out through automatic air vent and pressure gauge is showing the value between 1,5 and 2,5 bar (closed systems). Air vent is to be set at the highest point of the (closed) central heating system. If the pressure is below 1,5 bar the filling process must be repeated.

For open systems, working pressure depends on the overall height of the system and the open expansion vessel (1 bar for each 10 m is an estimate).

After the filling process is done, it is obligatory to close the drain tap valve, close the water supply to the water-filling pipe and detach the water-filling pipe.

An expert should be entrusted with the mounting of the heating and the initial operation. This must be a person who will take over the responsibility and guarantee the correct operation of the boiler and of the complete central heating system. In the case of an incorrectly planned system with manifesting deficiencies caused by the respective person's incorrect installation of the system, which can again lead to an incorrect operation of the boiler, the complete liability for the material damage and potential new costs arising in relation to it is borne exclusively by the person who was entrusted with the mounting of the central heating system, and not by the boiler manufacturer, sales representative or seller.

3 Boiler operation

First putting into operation is performed exclusively by a skilled person. Before putting in operation please make sure that:

- boiler is connected on central heating installation properly
- there is no air in the central heating installation and pressure is within range
- proper working cycle for circulation pump is chosen.

Heating by solid fuel (manual operation) can be performed in two ways:

1. Heating from above – put coal (or wood) over the fireplace pipes (“grid”) (no ash should be present). The draught regulator is at the maximum position. Using a tiny piece of wood or coal, light a fire on the top. When the fire begins to burn, draught regulator is set on desired temperature / position.

2. Heating from below – put small amount of solid fuel over the fireplace pipes (“grid”) (no ash should be present) and set up a fire. The draught regulator is at the maximum position. When the fire begins to burn, add larger amount of fuel and set draught regulator on desired temperature / position.

Make sure that lower boiler doors are closed during boiler use.

In case of an uncontrolled increase of pressure and temperature of the water in the boiler, due to various reasons (such as power failure causing interruption of the circulation pump operation, circulation pump defect, uncontrolled entry of air into system) close all air supply to the boiler or eventually take the fire out if the safety conditions allow that (there are no inflammable materials in the area). In case of power failure put the draught regulator in the zero position and the flap on the boiler chimney take-up in the closed position.

It is obligatory to pay special attention that the pressure inside the installation is within range ($> 1,5$ bar for closed systems). If the pressure is below the critical value, stop the boiler operation and refill the system when the boiler is cold.

The water hardness may not exceed the recommended value. If you heat the boiler using coal, depending on the kind of coal and quality of combustion, boiler is to be cleaned at least every 30 days. Dirtier the boiler, the efficiency of the system is smaller.

It is not allowed to extinguish the fire in the boiler artificially, it is forbidden to sprinkle the water inside the heating chamber. After the heating season boiler should be cleaned from ash and soot and the chamber should be treated with some protection agent against corrosion.

In case of any mechanical problem (the draught regulator is blocked, or the circulation pump is defect) stop the boiler operation first – only when the boiler is cold, reparation action can be undertaken.

4 Chimney

The purpose of the chimney is to take out the products of combustion but also to secure necessary air draught in the boiler. The graph shows how to choose the necessary height for the chimney as a function of chimney opening.

For instance, if we have a 160 mm diameter of the chimney, minimum chimney height would be 8 m for a 25 KW boiler or 11 m for a 30 KW boiler.

For a 180 mm diameter chimney should be at least 6 meter high for a 25 KW model, 7,5 m for 30 KW on the other side.

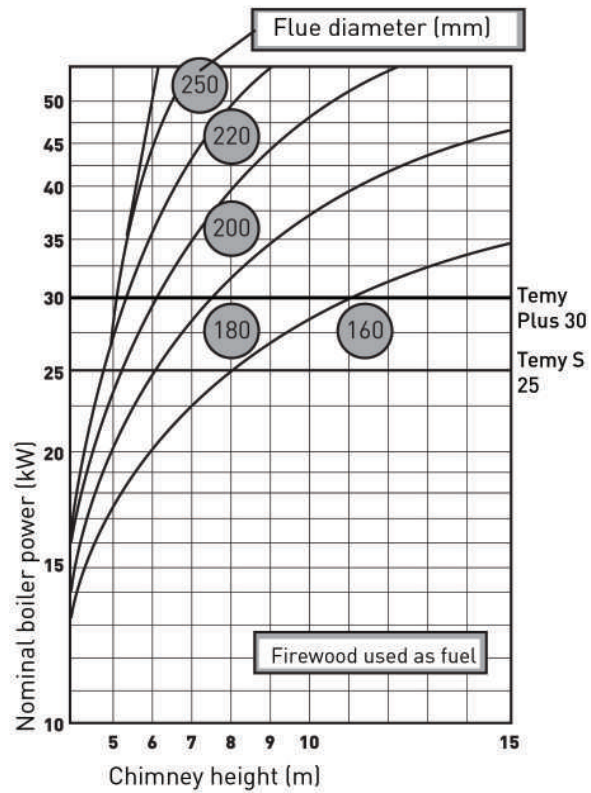

5 Boiler cleaning and maintenance

It is recommended that the boiler is cleansed from ash once to two times weekly. A detailed cleansing of the boiler should be done once a month and also when the heating season ends. Regular maintenance extends the service life of the boiler.

A Declaration Of Conformity



Hereby we, Termomont d.o.o. with legal seat in Prhovacka bb, 22310 Šimanovci, Serbia, declare under our sole responsibility that the following product(s):

Heating stove-boilers for solid fuel (wood, coal) TEMY S 10, TEMY S 15, TEMY S 25

manufactured in the following period: 2010-2011
to which this declaration relates, are in conformity with the following standard(s), or other normative document(s):

- EN 12809:2001

following the provisions of the directive:

- 97/23 WE

certified by notified body: Technický Skusobný Ústav Piestany, Slovak republic
Test report: No.93000019

Šimanovci, April 20, 2010

Authorized person

.....