

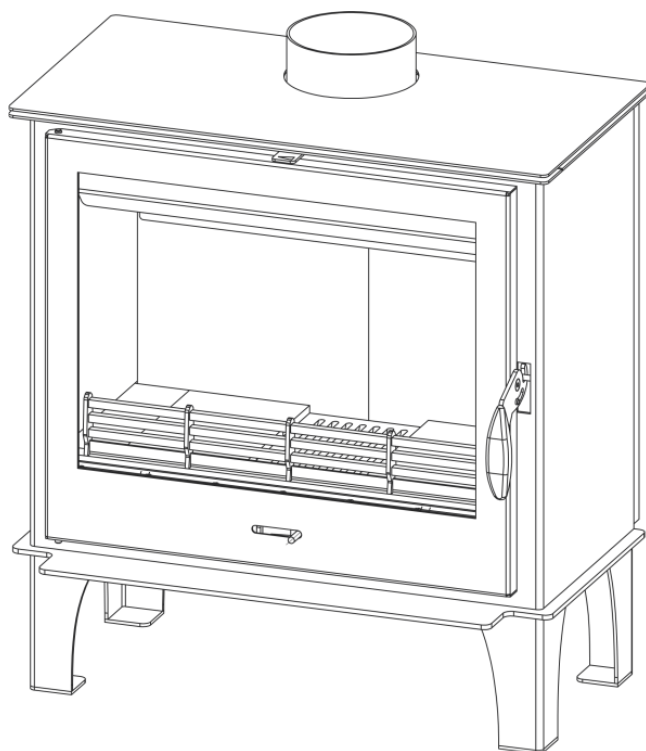

# TS-L

Owners's manual

INSTALATION, ADJUSTMENT AND OPERATING INSTRUCTION



CE

EN 13240

Dear Customer,

We appreciate your trust vested in us and decision to use "TIM SISTEM" product.

You have invested in energy-efficient and high-quality product - TS-L wood burning stove.

Your purchase will provide you long-term clean and comfortable heating with minimal maintenance.

Please read these instructions carefully and completely.

Its purpose is to inform you about the installation, operation and maintenance of your stove. Keep it handy and refer to it as needed. You will find in it information that will be useful now and in the years to come.

Make sure that when installing the stove all security standards have been respected and that all gas pipes, connections between tubes and pipes and walls are connected properly.

Failure to comply with these standards and carelessness during installation can result in damage to property or put your health and life in danger!

Set your stove to a safe place, away from the frequent passages and doors, somewhere near chimney and chimney connection.

We wish you many pleasant moments with TS-L.

**TIM SISTEM d.o.o.**

## **WARNING BEFORE USE**

To keep your stove working properly, it is important to read this manual and strictly stick to the instructions for use and handling.

For combustion use solid fuels such as wood and wood briquettes. It is forbidden putting explosive devices and materials combustion chamber or the limited thermal furnace. It is forbidden to keep flammable materials near the stove.

For proper combustion, in normal operating mode, draft in the chimney should be 10-14 Pa. If the draft is greater than 15 Pa, the valve should be installed in the chimney.

Room where the stove is positioned must be vented regularly for the fresh air needed for combustion.

Some parts of stove heat up during operation and it takes appropriate precaution when handling it. Do not allow children to handle and play near the stove.

Only spare parts recommended and allowed by the manufacturer should be installed on the stove. You must not make any changes on the stove.

With first firing there might show a mild smoke, especially from the plate's surface. It is a common appearance that occurs due to combustion deposits on the plate's surface (corrosion protection, paint, dust, ....). The room where the stove should be vented during the first firing.

It's not recommended connecting the stove to the common chimney because it can adversely affect the required draft.

Device that uses gas as fuel must not be connected to same chimney.

During firing, use protection gloves because the door handles get heated.

National and local regulations for the installation of the furnace must be respected.

**In a case of non-compliance with instructions given in this manual, manufacturer does not take any kind of responsibility for caused damage.**

## DESCRIPTION OF THE STOVE

TS-L wood burning stove is used for heating rooms and it's manufactured and tested according to European standard EN 13240.

The upper plate of the fireplace is made of steal.

Firebox doors are made of cast iron with fireproof glass.

Connection for smoke drainis being put on the plate and connected with screws.

All the materials that TS-L stove is made can be recycled.

Sealing elements are made of materials that contain asbestos.

### Parts of the stove:

1. Firebox doors
2. Primary air regulator
3. Secondary air regulator
4. Upper plate
5. Smoke drain
6. Lever
7. Glass
8. Grid carrier

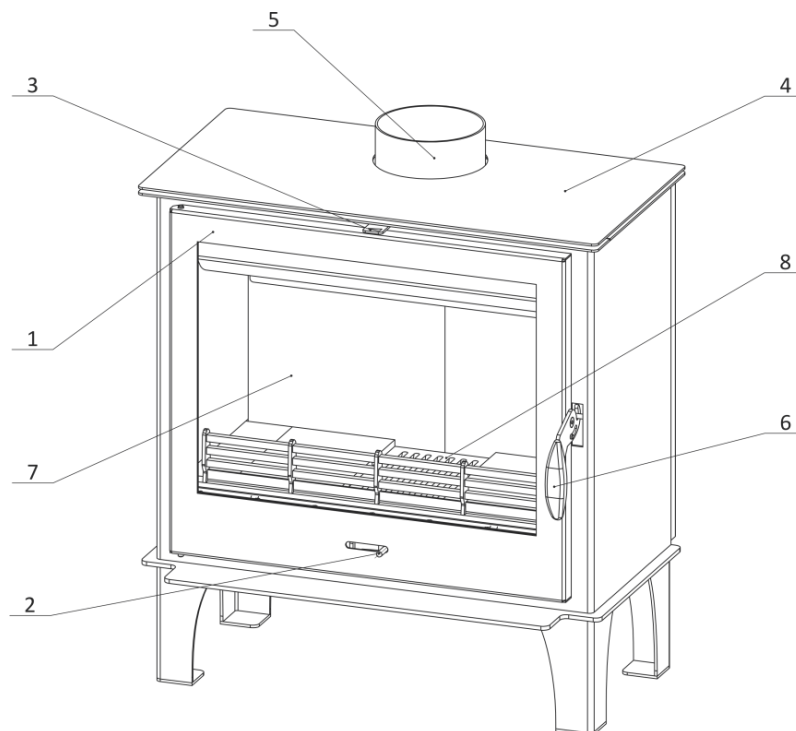

## TECHNICAL DATA

Name		TS-L
Use		Solid fuel stove
Nominal power	kW	9,7
efficiency	%	75,9
Fuel		Wood, wood briquets
Dimensions of the stove WxLxH []	mm	705x434x760
Dimensions of the fire place WxLxH [mm]	mm	612x286x315
Weight	kg	111
Minimum distance from flammable materials		
Back	mm	500
Side	mm	500
Front	mm	1400
Content CO (reduced on 13% O <sub>2</sub> )	%	0,0869
Dust content in flue gas	mg/Nm <sup>3</sup>	26,6 ( ≤ 75 )
Chimney connection	mm	Ø150
Chimney connection position		Central on upper plate
Consumption by nominal power	kg/h	2,81
Emission temperature	°C	275
Air regulation		Primary
		Secondary
Required draft	Pa	12±2

## DIMENSIONS OF THE STOVE

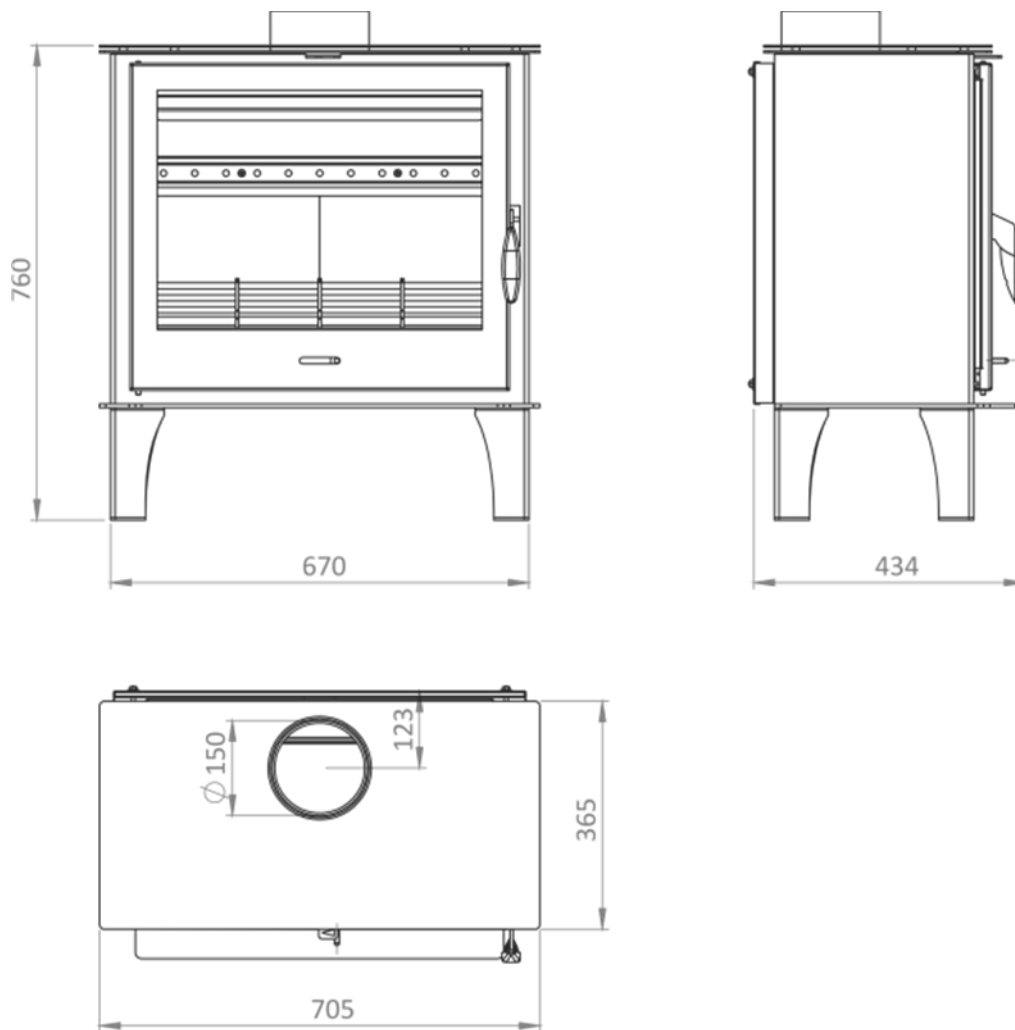

## INSTALLING THE STOVE

Stove must not be set up near the wooden parts, refrigeration parts, plastic furniture and other flammable materials because during operation (during fuel combustion) it achieves high operating temperature that is distributed on the outside of the furnace. Minimum distance between the stove and the surrounding elements is 50 cm, and the from flammable materials 80 cm.

If the ground on which you set the stove is made of easily flammable material (wood, warm floor, laminate ...) you need to set under the stove a protection sheet metal - lateral width of 10 cm and 50 cm in the front.

Because of its weight, the stove must be installed on the appropriate base. If it does not satisfy necessary standard, you must take appropriate measures to make it possible (eg, weight distribution).

Connect the stove to a chimney and flue pipes through the connector on top of the furnace, so as to ensure adequate tightness and flow of smoke from the stove to the chimney. Flue pipe must not be drawn too deeply into the chimney that would reduce the cross sectional area and thus undermined draft in the chimney. Do not use reducers which reduce the cross section of pipe smoke.

The stove requires insertion of fresh air in the room where it is installed, with surface openings for insertion of fresh air should not be less than  $0.4 \text{ dm}^2$ . The unit for fresh air set outside the common room for ventilation, which must be insured by door and grille.

Fans that work in the same room where the stove is installed may make interference with the stove. Also, all devices or ventilation that creates negative pressure in the room where the stove is installed, must be set in the way that does not make decompression that prevents normal operation of the furnace.

Before installing the stove, check the chimney drafts because it is a key factor in the proper functioning of the stove. Draft depends on the proper operation of the chimney and meteorological conditions. One of the easiest ways to check the draft in the chimney is with a candle flame, as shown in Figure 2. Put a candle near the chimney connection drain. If the flame bends towards drain, the draft is satisfying (Figure 2b). If the flame doesn't bend or bends a little, that indicates poor draft (Figure 2a).

If there is poor draft in the chimney (Figure 2a), check the chimney operation. The chimney should be located inside the building, and if it's located on the external walls of the building, it's recommended insulation chimney.

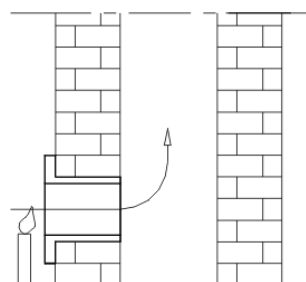

Figure 2a.

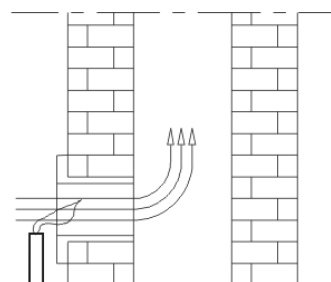

Figure 2b.

**Disadvantages of the chimney (Figure 3):**

1. The chimney is higher than the top of the roof, a small cross section of the output,
2. Excessive slope
3. A sudden change of direction of the flue channel
4. Stove or some other device connected to the same flue channel,
5. Bulges in the flue channel
6. Cracks
7. Alien body or accumulated grime,
8. Tube inserted too deeply,
9. Fan or other device that creates a vacuum in the room
10. Unsealed or opened cleaning hole

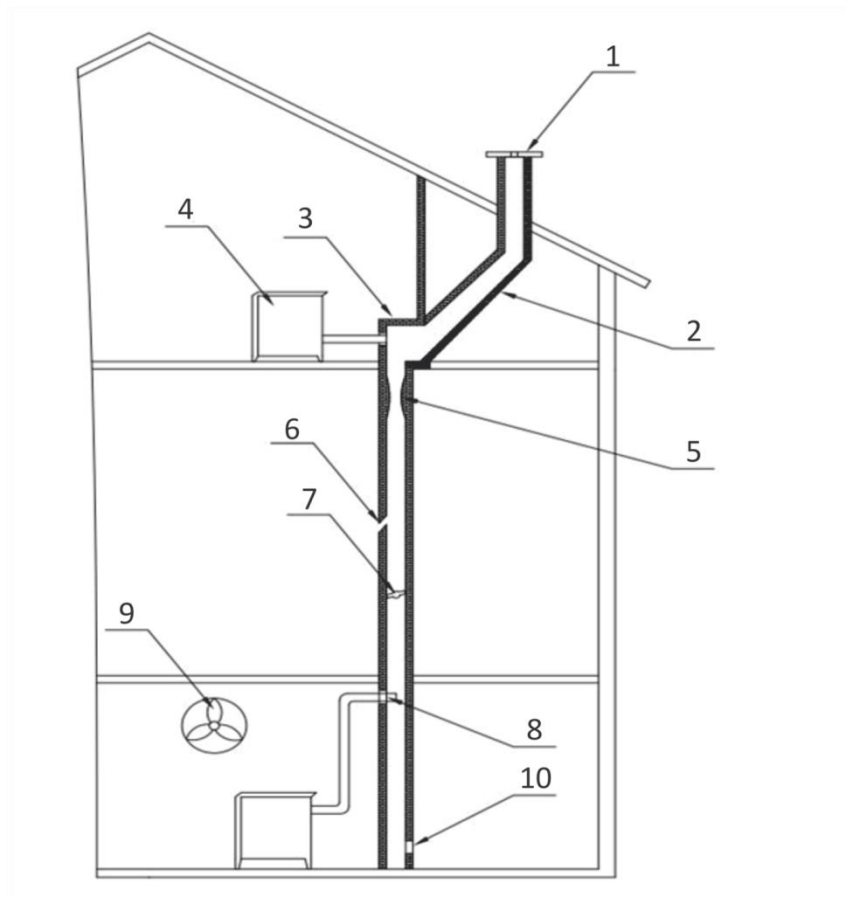

Figure 3.



## IGNITION AND LIGHTING

Before the first firing, wipe all painted surfaces with clean and dry cloth, in order to avoid burning impurity on the oven and creation of unpleasant smells.

Start the fire in the stove by following order:

- open the fire door,
- place the fuel into the fire place (chopped wood to non greasy wrinkled paper)
- light a fire
- leave open primary air regulator until the flame gets stable and after having stabilized the flame, control burning intensity with draft regulator (Fig. 1, pos. 2)
- secondary air regulator leave opened until the flame gets stable and after having stabilized the flame, control burning intensity with regulator (Fig. 1, poz.3)
- close the firebox door,
- after creating a basic flame insert larger pieces of wood or briquettes in the firebox, and close the firebox door. If you use briquettes as a fuel, you must wait that all briquettes are lit and then reduce the draft in half.
- when adding fuel, (Fig. 1, pos. 1) open the fire door step by step wait for 4-5 seconds, and then slowly open it wide.

Do not open the doors suddenly, when there's a strong flame in the combustion chamber, it may come to it's spreading into the room.

Regulating the draft in the stove, you can regulate temperature, power and the combustion of fuel, and this is done by running draft regulator on the firebox door (Fig. 1, pos. 2). Combining primary air through the regulator on the firebox door and secondary air over the leverage above the firebox door (Fig. 1, pos. 3) you get desired combustion .

Stove contains auxiliary tools in order to facilitate its maintenance.

Stove has a lever for shaking grid, located in the front of the stove, by slow back and front movements while the stove is running, which allows the passage of primary air.

Recommended fuels are briquettes and wood.

You must not use gasoline and similar fuels, because by using liquid fuels you create conditions for damaging the stove and to provoke an explosion.

## **Attention!**

- Do not use organic waste as fuel, food residue, plastic, combustible or explosive materials, which combustion disturbs the proper functioning of the stove and may cause damage and environmental pollution.
- Increased ambient temperature can cause poor air circulation (drafts) in the chimney, and in that case is recommended more frequent firing in smaller quantities.
- Avoid using the oven when there are bad weather conditions for the the oven and in the case of strong wind, because it reflects the required vacuum in the chimney. In these cases there may occur potential return of smoke in the room where the stove is placed. Ignition is difficult then.

We recommend firing every hour with the amount of fuel in the combustion chamber up to 15cm with cross stacking wood for better airflow.

After each refilling, it's recommended to leave the oven running in full speed for 30 minutes, in order to destroy all volatile elements that may cause condensation in the oven.

For correct stove operation it takes:

- Regular cleaning of the stove and chimney
- Regular room ventilation for better combustion
- Regular ash tray cleaning
- Accumulated slag and unburned material regularly remove from the grid

## **HANDLING THE STOVE OPERATION**

Start a fire with a moderate flame in order to avoid thermal shocks.

The following amounts of wood are inserted only after the previous volume burn.

Do not allow that ashes and unburned accumulate on the grid and to tap that way. Clean the grid.

Open the door slowly and carefully, allowing that way equalization of pressure in the firebox and in the room, otherwise it might cause the smoke in the room.

The stove is designed and intended for use with firebox door constantly closed, except during refueling. Do not open the door with no need.

The wood must be a maximum of 20% moisture content for maximum fire effect. Otherwise the tar gets separated which with water steam may create creosote. If that happens in some bigger quantity, it may lead to a chimney fire. You will most easily recognize chimney fire by: the characteristic sound that comes out of the chimney like loud roaring, visible flames coming out of the chimney, high ambient temperatures of surrounding walls and the characteristic smell of burning.

If there comes to the fire do the following:

- Immediately call the fire squad
- muffle oxygen supply to the chimney and turn off the stove
- Do not insert anything into the chimney and make sure that the fire does not spread to the wooden construction or other combustible materials in its nearby.
- DO NOT pour water into the stove or chimney
- A fire in the chimney can be extinct only with dry powder
- Water can extinguish only a surrounding material
- Do not cool the surrounding walls with water

Note:

If the fire in the stove for some reason becomes dangerously strong take the following measures: close air dampers that provide air for combustion. If it is necessary put in the firebox specially prepared sand for this purpose or non-combustible fire blanket. It would be good to have a fire extinguisher.

Before the second charging, clean the grid in order to provide the fresh air.

Regularly clean the ash pan making sure that there is always a place for ashes.

The furnace is designed to operate in periodic mode. To maintain the required nominal power, combustion chamber is periodically filled with prestabled amount of fuel.

Furnace is not designed to operate in continuous mode of heating or in accumulating temperature mode.

## I - regulation of primary air

Primary air regulator set to the open position (Figure 4a) during ignition and hold in this position until the stove operation gets stable, after insertion of larger wood or briquette pieces. After that, the controller set to the closed position (for burning wood and wood briquettes - Figure 4b) and keep it in that position when the oven. When closed, the regulator prevents the air intake below the grille, which reduces the intensity of the fire. If the fuel is of poor quality, partially open the regulator.

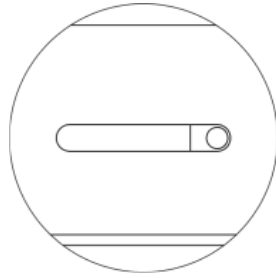

Figure 4a.

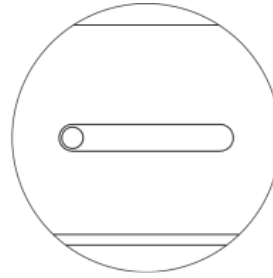

Figure 4b.

## II - secondary air control

Secondary air regulator set to "max" (Figure 5) during ignition and hold in this position until the establishment of a stable stove operation after insertion of larger pieces of wood or briquettes. After that, depending on what position is the regulator will depend the intensity of the combustion. If the secondary air regulator remains in the open position, intensity of burning will be maximized and if the secondary air control in the "min", intensity burning will be minimal.

Stoves power control is obtained by adjusting the regulator of the primary and secondary air.



Figure 5a.



Figure 5b.

## CLEANING AND MAINTENANCE

Regular and proper cleaning allows proper operation and long life of the stove. All cleaning the interior or exterior surfaces are always performed in a cold oven.

Cleaning exterior surfaces - is done with a soft cloth that will not damage the surface of the stove. Cleaners of chemical origin can damage the surface of the fire place and cannot be used. Painted surfaces must not be cleaned with abrasive products.

Cleaning inter surfaces –when cleaning use protective gloves.  
Clean the bottom of the oven from accumulated ash and pick up small unburned pieces of the grid, clean the ashtray and ash accumulated in the interior of the fireplace.

Cleaning glass surfaces - glass on the firebox may get dirty during the operation.. For cleaning use a mild detergent. Do not use abrasive cleaners because they can damage the surface of the glass. Clean the glass only when cool.

Cleaning and maintenance of the chimney - chimney cleaning and control is recommended at least once a year and after a long downtime. Regular maintenance and control of the chimney will prevent the occurrence of fire and poor operation of the stow.

### Malfunction. Recommendations for its elimination

The following table shows the most common defects and recommendations for their removal.  
Table: Showing the most common malfunctions, possible causes and ways of eliminating it.

Malfunction	Possible cause	Howe to remove it
Oven heats poorly	improper handling, Poor uptake	Read carefully and follow the instructions. Inthe case that despite all instructions have been respected, malfunctions are still not removed, call the customer service
Difficulties in lighting fire	Closed regulator of air supply, Wet wood, Lack of oxygene	Open the regulator of air supply and provide a supply of a primary air Use a dry wood Ventilate a room in order to provide a supply of fresh air

Smoke reenters into a room	Closed regulator of air supply, Insufficient draft, Remainings of ashes on a grid	Open the regulator of air supply and provide a supply of a primary air Read carefully the instructions and apply advices how to provide a draft Clean the grid
Glass on a firebox door are getting sooty for a while	Wet wood Too much fuel Insufficient draft Closed intake of secondary air	Use a dry wood Check a suggested quantity of a fuel provided in a user's manual Check a connection with a chimney Read carefully the instructions and apply advices how to provide secondary air

## GENERAL RECOMMENDATION

If you have followed all the recommendations for installation, operation and control of cleaning, given in this manual, the stove is now tested, safe device for household use.

Before installing the stove, remove the package. Be aware of potential injuries because the wooden slats are connected with nails. Dispose a plastic bag in accordance with the regulations. Old stove you do not want to use anymore, dispose to designated areas in accordance with the regulations.

All complaints, perceived failure or malfunctioning stoves, should be reported to the factory or authorized service center by telephone or in written, only with fiscal receipt. All contact information provided at the end of this guide.

Any malfunction of the stove, must be removed by the manufacturer's service only.

If unauthorized persons carry out any servicing or repairs and alterations to the stove, the owner loses the right to the manufacturer's warranty.

Supply of spare parts has to be done via manufacturer's service, based on the position and image of this manual.

The manufacturer does not assume any responsibility if the buyer fails to comply with the instructions for use and installation of the stove.

# SOLID FUEL STOVE „TS-L“

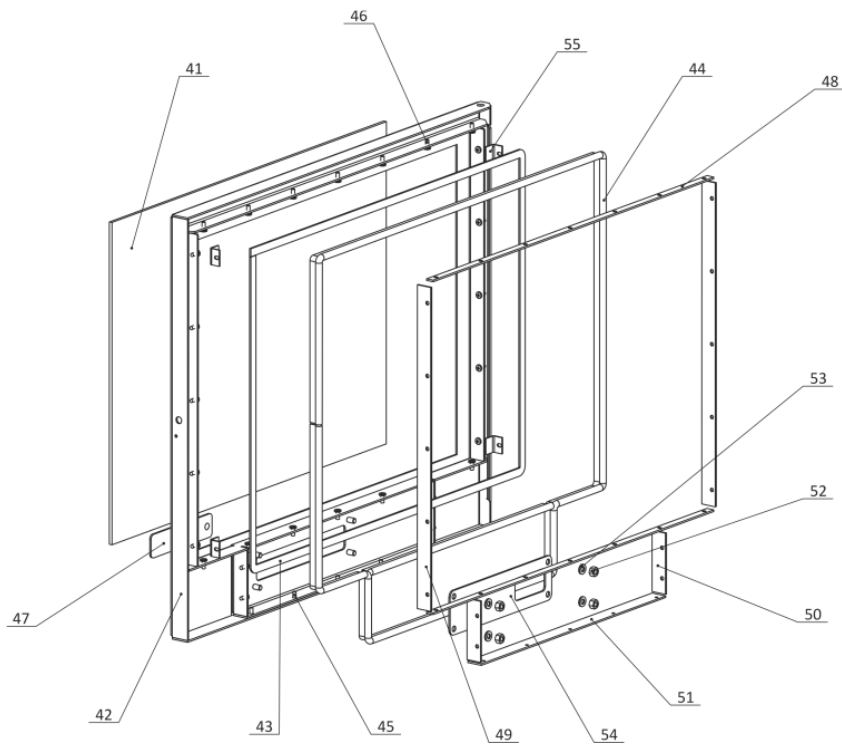
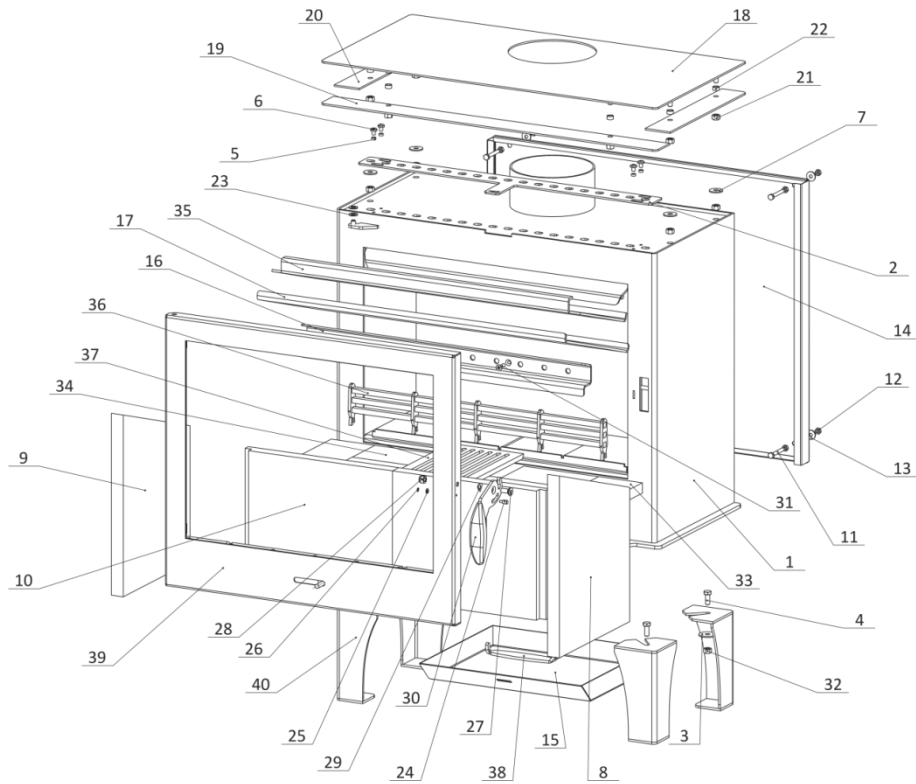

## List of all Positions on the "TS-L" stove

1. Corpus Stoves
2. Secondary air regulator
3. Washer feet
4. Screw feet
5. Bush for secondary air regulators
6. Screw the regulator of secondary air
7. Washer decorative top panel
8. Right side vermiculite
9. Left side vermiculite
10. Clearance vermiculite
11. Decorative screw back
12. Nut decorative screws back
13. Washer decorative screws back
14. Decorative back
15. Ashtray
16. Angle tertiary air
17. The lower deflector
18. Upper plaque
19. Front decorative inlay
20. Side decorative inlay
21. Upper nut decorative plates
22. Spacer sleeve upper decorative plates
23. Washer door
24. stopper lever
25. Washer stop lever
26. Nut stop lever
27. Screw the handle
28. Nut lever
29. Pleated washer lever
30. Subassembly door handles
31. Screw angle tertiary air
32. Nut feet
33. Fireclay brick furnace first
34. Fireclay brick furnace second
35. Upper deflector
36. Bumper in the furnace
37. Grid
38. Handle ashtrays
39. Subassembly door
40. Leg
41. Glass
42. Door
43. Asbestos adhesive tape glass
44. Asbestos-free sealing adhesive tape
45. Screw neck (cone head)
46. Screw neck (cylindrical head)
47. Primary air regulator
48. Horizontal longer handle tapes
49. Vertical long ribbon holder
50. Vertical shorter cord holder
51. Horizontal shorter cord holder
52. Nut cover primary air regulator
53. Washer lid primary air regulator
54. Cover primary air regulator
55. Glass holder



## **ADVICES FOR ENVIRONMENT PROTECTION**

### **PACKAGING**

Packaging material is 100% recyclable.

For a waste disposal of, act in accordance with local regulations.

Packaging material (plastic bags, polystyrene parts-polystyrene, etc.). Should be kept away from children, as a potential source of danger.

Take care of safe removing and disposing of wooden boards because they are connected with nails.

### **PRODUCT**

The device is made of materials that can be recycled. When disposing the waste, act in accordance with environmental laws in effect.

Use only the recommended fuel.

It is forbidden burning an inorganic and organic materials (plastics, plywood, textile, oiled wood, etc..), because the combustion releases carcinogenic materials and other toxics.

## WARRANTY

Stove will work well only if you follow the given instructions.

TIM SISTEM is obligated to provide spare parts and eliminate interference with the stove that are covered by this warranty within the time limit not exceeding 45 days from the date of defect report . If the defect is not corrected within 45 days, you have the right to a substitution for a new product.

The warranty is valid from the date of purchase, as evidenced by duly completed guarantee certificate, and the shop's receipt.

The warranty for this product is 24 months.

TIM SISTEM is obliged to provide spare parts in due time after the stove is no longer produced.

### **This warranty does not cover damage caused by:**

- **inadequate use of stoves;**
- **violating the instructions given in this manual;**
- **mechanical damage incurred due to inadequate storage and transport;**
- **due to mechanical damage caused by kicking, tumbling;**
- **due to inadequate exposure to rain, snow etc.;**
- **due to chemical damage caused by exposure to inflammatory agents such as**
- **oil and oil products, alcohol, solvents, paints;**
- **due to natural disasters such as lightning, floods, fire;**

The parts subjected to wear, such as braiding (glass), gaskets, rubber parts (rubber feet, spacers), are not covered by this warranty.

All malfunctions report in written or orally by telephone, on the address listed below:

Distributor / Authorized Service :



TIM SISTEM d.o.o.  
Prva Berbernička 9, Industrial area Nova Pazova.  
22 330 Nova Pazova, Pazova  
tel/fax: +381 22 328 076  
e-mail: [office@timsistem.rs](mailto:office@timsistem.rs)  
[www.timsistem.rs](http://www.timsistem.rs)